

7TH EDITION

HEAVY DUTY TRUCK SYSTEMS

SEAN BENNETT

We Support



Education Foundation

7TH EDITION

HEAVY DUTY TRUCK SYSTEMS

SEAN BENNETT

We Support



Education Foundation



Australia • Brazil • Mexico • Singapore • United Kingdom • United States

Heavy Duty Truck Systems, Seventh Edition**Sean Bennett**SVP, GM Skills & Global Product Management:
Jonathan Lau

Product Director: Matthew Seeley

Senior Product Manager: Katie McGuire

Product Assistant: Kimberly Klotz

Executive Director of Development: Marah Bellegarde

Learning Design Director: Juliet Steiner

Senior Learning Designer: Mary Clyne

Vice President Strategic Marketing Services: Jennifer
Ann Baker

Marketing Director: Sean Chamberland

Associate Marketing Manager: Andrew Ouimet

Senior Director Content Delivery: Wendy Troeger

Manager Content Delivery: Alexis Ferraro

Senior Content Manager: Sharon Chambliss

Senior Digital Delivery Lead: Amanda Ryan

Design Director: Jack Pendleton

Senior Designer: Angela Sheehan

Cover image(s): iStockPhoto.com/EasyBuy4u

Production Service/Composition: SPi Global

© 2020, 2016 Cengage Learning, Inc.

Unless otherwise noted, all content is © Cengage.

ALL RIGHTS RESERVED. No part of this work covered by the copyright herein may be reproduced or distributed in any form or by any means, except as permitted by U.S. copyright law, without the prior written permission of the copyright owner.

For product information and technology assistance, contact us
at **Cengage Customer & Sales Support, 1-800-354-9706**
or **support.cengage.com**.

For permission to use material from this text or product,
submit all requests online at **www.cengage.com/permissions**.

Library of Congress Control Number: 2018944693

Book Only ISBN: 978-1-3377-8710-9

Cengage20 Channel Center Street
Boston, MA 02210
USA

Cengage is a leading provider of customized learning solutions with employees residing in nearly 40 different countries and sales in more than 125 countries around the world. Find your local representative at **www.cengage.com**.

Cengage products are represented in Canada by Nelson Education, Ltd.

To learn more about Cengage platforms and services, register or access your online learning solution, or purchase materials for your course, visit **www.cengage.com**.

Notice to the Reader

Publisher does not warrant or guarantee any of the products described herein or perform any independent analysis in connection with any of the product information contained herein. Publisher does not assume, and expressly disclaims, any obligation to obtain and include information other than that provided to it by the manufacturer. The reader is expressly warned to consider and adopt all safety precautions that might be indicated by the activities described herein and to avoid all potential hazards. By following the instructions contained herein, the reader willingly assumes all risks in connection with such instructions. The publisher makes no representations or warranties of any kind, including but not limited to, the warranties of fitness for particular purpose or merchantability, nor are any such representations implied with respect to the material set forth herein, and the publisher takes no responsibility with respect to such material. The publisher shall not be liable for any special, consequential, or exemplary damages resulting, in whole or part, from the readers' use of, or reliance upon, this material.

CONTENTS



Contents for Photo Sequences vii
Preface. ix
Features of the Text. xi
Supplements.xiii
Acknowledgments xv

CHAPTER 1 Introduction to Servicing Heavy-Duty Trucks 1

1.1 Truck Classifications • 2 1.2 Heavy-Duty Trucks • 5 1.3 Career Opportunities for Heavy-Duty Truck Technicians • 12 1.4 Job Classifications • 15 1.5 Advancement in the Profession • 20 1.6 Electronic Logging Devices • 22 1.7 Autonomous and Electric Trucks • 23

CHAPTER 2 Shop Safety and Operations 27

2.1 Personal Protective Equipment • 28
2.2 Work Area Safety • 32 2.3 Oxyacetylene Equipment • 37 2.4 Electric Arc Welding • 40
2.5 Shop Tool Safety • 40 2.6 Hazardous Materials and WHMIS • 40 2.7 Handling and Disposal of Hazardous Waste • 41 2.8 Shop Records • 45 2.9 Lockout/Tagout • 48

CHAPTER 3 Tools and Fasteners 52

3.1 Hand Tools • 53 3.2 Power Tools • 64
3.3 Measuring Tools • 69 3.4 Manufacturers' Service Literature • 78 3.5 Fasteners • 84

CHAPTER 4 Maintenance Programs 96

4.1 VMRS • 100 4.2 Setting Up a Maintenance Program • 102 4.3 Out-of-Service or Deadlining a Vehicle • 110 4.4 PM Scheduling • 116
4.5 Lubricants • 120 4.6 Winterizing • 127
4.7 Performing a Lube Job • 135 4.8 Fleet

Management Software • 137 4.9 Maintaining Emissions Control Equipment • 138

CHAPTER 5 Fundamentals of Electricity 141

5.1 Atomic Structure and Electron Movement • 142 5.2 Conductors and Insulators • 147 5.3 Current Flow • 148 5.4 Magnetism • 149
5.5 Electromagnetism • 150 5.6 Electrical Current Characteristics • 152 5.7 Sources of Electricity • 153 5.8 Electrical Circuits and Ohm's Law • 155 5.9 Electric Motor and Generator Principle • 162 5.10 Coils, Transformers, and Solenoids • 165

CHAPTER 6 Fundamentals of Electronics and Computers 170

6.1 Using Electronic Signals • 171
6.2 Semiconductors • 173 6.3 Diodes • 175
6.4 Transistors • 177 6.5 Photonic Semiconductors • 180 6.6 Testing Semiconductors • 181 6.7 Integrated Circuits (I/Cs) • 183 6.8 Gates and Truth Tables • 184 6.9 Binary System Basics • 185
6.10 Microprocessors • 187 6.11 Data Retention in a Vehicle ECU • 196 6.12 Auxiliary Electronic Systems • 197 6.13 Accident Avoidance Systems • 198

CHAPTER 7 Batteries 206

7.1 Battery-Operating Principles • 207
7.2 Battery Ratings • 214 7.3 Battery Classifications • 215 7.4 Battery Maintenance • 216 7.5 Battery Testing • 219
7.6 Charging the Battery • 225 7.7 Conductance Testing • 231 7.8 Alternative Battery Technology • 236 7.9 Ultracapacitors and Supercapacitors • 237 7.10 Battery Management Systems • 238

CHAPTER 8 Charging Systems 242

- 8.1 Alternator Construction • 243
- 8.2 Alternator Operation • 246
- 8.3 Charging System Failures and Testing • 250
- 8.4 Alternator Rebuild • 255

CHAPTER 9 Cranking Systems 264

- 9.1 Cranking Circuit Components • 265
- 9.2 Starter Motors • 268
- 9.3 Cranking Circuit Testing • 275
- 9.4 Starter Rebuild • 281

CHAPTER 10 Chassis Electrical Circuits 286

- 10.1 Lighting Systems • 287
- 10.2 Auxiliary Electrical Equipment • 296
- 10.3 Rapid Checking of a Truck Electrical Circuit • 307

CHAPTER 11 Diagnosis and Repair of Electronic Circuits 315

- 11.1 Types of EST • 317
- 11.2 Using Digital Multimeters • 320
- 11.3 Multifunctional Handheld Diagnostic Tools • 331
- 11.4 Handheld Diagnostic Instruments • 331
- 11.5 PCs and OEM Software • 336
- 11.6 Oscilloscopes • 341
- 11.7 Electronic Troubleshooting • 343
- 11.8 Bus Codes and Protocols • 346
- 11.9 Troubleshooting CWS and CMS • 347
- 11.10 Electrical Wiring, Connector, and Terminal Repair • 349
- 11.11 Wiring Schematics • 354
- 11.12 Supplemental Restraint System • 359

CHAPTER 12 Multiplexing 367

- 12.1 Multiplexing, Clients, and Servers • 369
- 12.2 Multiplexing Basics • 369
- 12.3 Multiplex Switching • 377
- 12.4 Multiplex Transactions • 379
- 12.5 Accessing the Data Bus • 381

CHAPTER 13 Hydraulics 390

- 13.1 Fundamentals • 391
- 13.2 Hydraulic Components • 397
- 13.3 Pumps • 398
- 13.4 Actuators • 407
- 13.5 Hydraulic Motors • 409
- 13.6 Conductors and Connectors • 411
- 13.7 Hydraulic Fluids • 418
- 13.8 Symbols and Schematics • 419
- 13.9 Maintenance • 420

CHAPTER 14 Clutches 428

- 14.1 Clutch Function • 428
- 14.2 Clutch Components • 429
- 14.3 Troubleshooting • 441
- 14.4 Maintenance • 443
- 14.5 Clutch Servicing • 453

CHAPTER 15 Standard Transmissions 476

- 15.1 Main and Auxiliary Gearing • 477
- 15.2 Geartrain Configurations • 484
- 15.3 Mechanical Shift Mechanisms • 484
- 15.4 Shift Housing Assembly • 494
- 15.5 Twin-Countershaft Transmissions • 498
- 15.6 Auxiliary Gear Sections • 498
- 15.7 Transfer Cases • 514

CHAPTER 16 Standard Transmission Servicing 522

- 16.1 Lubrication • 522
- 16.2 Preventive Maintenance Inspections • 525
- 16.3 Troubleshooting • 529
- 16.4 Transmission Overhaul • 535
- 16.5 General Overhaul Guidelines • 539
- 16.6 Step-By-Step Overhaul • 539
- 16.7 Troubleshooting Air Shift Systems • 555

CHAPTER 17 Torque Converters 563

- 17.1 Torque Converter Construction • 564
- 17.2 Principles of Operation • 568
- 17.3 Maintenance and Service • 575

CHAPTER 18 Automatic Transmissions 585

- 18.1 Planetary Gearset Components • 586
- 18.2 Compound Planetary Gearsets • 593
- 18.3 Transmission Hydraulic Systems • 602
- 18.4 Hydraulic Retarders • 610

CHAPTER 19 Automatic Transmission Maintenance 613

- 19.1 Inspection and Maintenance • 614
- 19.2 Shift Point Adjustments • 623
- 19.3 Power Take-Offs (PTOs) • 629

CHAPTER 20 Automated Manual and Hybrid Transmissions 631

- 20.1 Transmission Identification • 633
- 20.2 Ultrashift Components • 635
- 20.3 Transmission ECU • 642
- 20.4 Fault Detection and Data Links • 646
- 20.5 AMT Clutch Actuators • 649
- 20.6 Hybrid Transmissions • 650

CHAPTER 21 Electronically Controlled Automatic Transmissions (ECATs) 657

- 21.1 ECAT Management • 659
- 21.2 Allison DOC • 663
- 21.3 WT Transmissions • 664
- 21.4 Allison TC10 • 695
- 21.5 Caterpillar CX Truck Transmissions • 714
- 21.6 Voith DIWA Transmission • 723
- 21.7 Navigating ECU Schematics • 723

CHAPTER 22 Driveshaft Assemblies 728

- 22.1 Driveshaft Construction • 729
- 22.2 Driveshaft Inspection • 736
- 22.3 Lubrication • 737
- 22.4 U-Joint Replacement • 739
- 22.5 Chassis Vibration Diagnosis • 745

CHAPTER 23 Heavy-Duty Truck Axles 754

- 23.1 Drive Axles • 756
- 23.2 Power Dividers • 765
- 23.3 Two-Speed Drive Axles • 772
- 23.4 Drive Axle Shaft Configurations • 778
- 23.5 Nondriving Axles • 778

CHAPTER 24 Heavy-Duty Truck Axle Service and Repair 784

- 24.1 Drive Axle Lubrication • 785
- 24.2 Truck Axle Cleaning and Inspection • 788
- 24.3 Carrier, Axle, and Gearing Identification • 789
- 24.4 Failure Analysis • 789
- 24.5 Axle Adjustments and Checks • 806

CHAPTER 25 Steering and Alignment 817

- 25.1 Steering System Components • 818
- 25.2 Front-End Alignment • 823
- 25.3 Electronic

- Alignment Systems • 834
- 25.4 Steering Axle Inspection • 838
- 25.5 Manual Steering Gears • 849
- 25.6 Power-Assist Steering Systems • 855
- 25.7 Troubleshooting Power Steering Systems • 859
- 25.8 Rack and Pinion Steering • 863
- 25.9 Electronic and Load-Sensing Steering • 864
- 25.10 Commercial Vehicle Safety Alliance (CVSA) OOS Steering Criteria • 868

CHAPTER 26 Suspension Systems 871

- 26.1 Leaf Spring Suspensions • 872
- 26.2 Cushion and Torsion Suspensions • 879
- 26.3 Air Spring Suspensions • 882
- 26.4 Servicing Mechanical Suspensions • 885
- 26.5 Servicing Equalizing Beams • 892
- 26.6 Servicing Air Suspensions • 896
- 26.7 Suspension Alignment • 902
- 26.8 Roll Stability Control • 905
- 26.9 Cab Air Suspensions and Driver Seats • 906
- 26.10 Ride Analysis • 908

CHAPTER 27 Wheels and Tires 912

- 27.1 Wheels and Rims • 913
- 27.2 Tires • 918
- 27.3 Tire Maintenance • 923
- 27.4 Tire, Rim, and Wheel Service • 928
- 27.5 Wheel Balancing • 942
- 27.6 Chassis Tire Pressure Management • 946
- 27.7 Wheel Hubs, Bearings, and Seals • 949
- 27.8 Wheel Bearing Adjustment • 955
- 27.9 Wheel Seal Service • 958
- 27.10 Wheel End Conclusion • 962

CHAPTER 28 Truck Brake Systems 966

- 28.1 Air Brakes: A Driver's Point of View • 968
- 28.2 Air Brake Subsystems • 970
- 28.3 The Air Supply Circuit • 972
- 28.4 Primary Circuit • 982
- 28.5 Secondary Circuit • 984
- 28.6 Trailer Circuit • 989
- 28.7 Foundation Brakes • 992
- 28.8 Air Brake System Components • 998
- 28.9 Brake System Balance • 1017
- 28.10 Air Start Systems • 1020

CHAPTER 29 Hydraulic Brakes and Air-Over- Hydraulic Brake Systems 1024

- 29.1 Hydraulic Brake System Components • 1025
- 29.2 Air-Over-Hydraulic Brake Systems • 1037
- 29.3 Hydraulic Brake Service Procedures • 1038
- 29.4 Hydraulic ABS • 1050
- 29.5 CVSA OOS • 1053

CHAPTER 30
ABS and EBS 1058

- 30.1 Basics of ABS Operation • 1059
- 30.2 ABS Components • 1061
- 30.3 ABS Configurations • 1068
- 30.4 Automatic Traction Control (ATC) Systems • 1070
- 30.5 Trailer ABS • 1070
- 30.6 ABS Diagnostics • 1072
- 30.7 ABS Service Procedure • 1075
- 30.8 ABS Add-Ons • 1079
- 30.9 Electronic Braking Systems (EBS) • 1082

CHAPTER 31
Air Brake Servicing 1087

- 31.1 Maintenance and Safety • 1088
- 31.2 Test Equipment • 1091
- 31.3 Assessing Brake System Performance • 1093
- 31.4 Supply Circuit Service • 1098
- 31.5 Service Application Circuit • 1104
- 31.6 Parking/Emergency Circuit • 1110
- 31.7 Slack Adjusters • 1115
- 31.8 Trailer Brake System • 1118
- 31.9 Foundation Brake Service • 1119
- 31.10 Brake Adjustment • 1126
- 31.11 General Brake Valve Troubleshooting • 1132
- 31.12 Service Procedures on Air Disc Brakes • 1134
- 31.13 Servicing Wedge Brakes • 1137
- 31.14 Brake Certification, Inspection, and Testing • 1137
- 31.15 Commercial Vehicle Stopping Distances • 1139

CHAPTER 32
Vehicle Chassis Frame 1143

- 32.1 Basic Frame Terms • 1144
- 32.2 Frame Theory • 1145
- 32.3 Frame Construction • 1149
- 32.4 Frame Damage • 1152
- 32.5 Frame Alignment • 1154
- 32.6 Repair of Frame, Side Rails, and Cross-Members • 1157

CHAPTER 33
Heavy-Duty Truck Trailers 1167

- 33.1 Tractor/Trailer Combinations • 1168
- 33.2 Freight Van Trailers • 1172
- 33.3 Refrigerated and Insulated Vans • 1176
- 33.4 Specialty Trailer Designs • 1180
- 33.5 Trailer Undersides • 1183
- 33.6 Trailer Maintenance • 1190
- 33.7 Testing Trailer Air and Electrical Circuits • 1194

CHAPTER 34
Fifth Wheels and Coupling Systems 1198

- 34.1 Types of Fifth Wheels • 1199
- 34.2 Fifth Wheel Height and Location • 1203

- 34.3 Principles of Fifth Wheel Operation • 1203
- 34.4 Fifth Wheel Maintenance • 1210
- 34.5 Coupling • 1215
- 34.6 Mounting Fifth Wheels • 1216
- 34.7 Sliding Fifth Wheels • 1218
- 34.8 Kingpins and Upper Couplers • 1220
- 34.9 Pintle Hooks/Ball Hitches • 1222
- 34.10 Coupling Device CVSA OOS • 1224

CHAPTER 35
Heavy-Duty Heating, Ventilation, and Air Conditioning Systems 1228

- 35.1 Principles of Refrigeration • 1229
- 35.2 Refrigerant • 1231
- 35.3 The Refrigeration Cycle • 1235
- 35.4 Air Conditioning System Components • 1236
- 35.5 Safety Precautions • 1251
- 35.6 Performance Testing an Air Conditioning System • 1252
- 35.7 Air Conditioning Service Equipment • 1255
- 35.8 Air Conditioning Service Procedures • 1259
- 35.9 Common Air Conditioning Problems • 1267
- 35.10 Converting an R-12 System to an R-134A System • 1269
- 35.11 Cab Ventilating and Heating Systems • 1270
- 35.12 Liquid-Cooled Heating System • 1271
- 35.13 Electronically Managed Climate Control • 1275
- 35.14 Bluecool Truck Thermal Storage System • 1280

Appendix A	Acronyms.....	1283
Appendix B	Truck Nominal Class Designations	1288
Appendix C	Brake Shoe Identification Chart.....	1289
Appendix D	Vibration Diagnosis	1290
Appendix E	Hard Steering Troubleshooting Flow Chart	1292
Appendix F	Dual Circuit Brake System Troubleshooting	1293
Appendix G	Driveline Configurations	1297
Appendix H	Measuring Driveline Angles	1298
Appendix I	Vehicle Configurations	1299
Appendix J	Quick Conversion Formula.....	1300
Appendix K	J1939 Message Decoder.....	1301
Appendix L	Tire Code Interpretation and Tread Pattern Designations.....	1302
Glossary	1303
Index	1345

Photo Sequences

1	Micrometer Familiarization	74
2	Repairing Damaged Threads	91
3	Testing Truck Batteries	235
4	Performing a Rapid Assessment of a Truck Electrical Circuit	309
5	Accessing a Truck Data Bus with an EST.....	386
6	Clutch Adjustment.....	447
7	Measuring Kingpin Wear and Vertical Play.....	844
8	Flow and Pressure Test a Hydraulic Assist Steering Gear System	861
9	Air Suspension Height Control Adjustment	898
10	Mount a Set of Duals to a Cast Spoke Wheel	930
11	Install a Set of Hub-Piloted Duals to a Wheel Assembly.....	938
12	Wheel End Procedure: TMC Method of Bearing Adjustment	957
13	Wheel Speed Sensor Testing	1078
14	Governor Adjustment	1095
15	Check Freestroke on S-CAM Foundation Brakes	1128
16	Wheel-Down Brake Adjustment Procedure on a Tractor/Trailer	1130
17	Wheel-Up Brake Adjustment Procedure on a Tractor/Trailer.....	1131
18	Measuring a Brake Rotor	1136
19	Tractor to Trailer Coupling Procedure	1217

PREFACE



ABOUT THE SEVENTH EDITION

The seventh edition of *Heavy Duty Truck Systems* adheres to the structure of the previous edition, a model that appears to work for most users. However, preserving this structure was not without its challenges and one outcome is that there are some lengthy chapters. There is content that might at first sight appear to be a generation out of date to someone whose exposure to the trucking landscape is confined to the technology on view in our largest fleets and OEM dealerships in major cities. The term *legacy vehicle* is often applied to older trucks but what constitutes an older truck is up for debate. In a top ten fleet, a legacy truck can be anything in the yard that is 4 years of age or older, while according to California legislators, it's anything prior to MY 2010. But the overall picture is different. In 2018, the *average* age of registered Class 8 tractors on our roads was 91 months (ACT Research) or 8 years and 7 months. The reality is that there are millions of aging trucks on our roads, and it is this segment of the national commercial fleet that occupies the most time spent in service and repair facilities. If you want proof of this, take a look at the threaded discussions on the HD online forum of the International Automotive Technicians Network (iATN). This is just a reminder that as educators we have a responsibility to be wary about how rapidly we replace the old with what's new.

TEACHING AND LEARNING

As with previous editions, this textbook focuses on the ASE Education Foundation learning competencies. In doing so, it reinforces the ASE Education Foundation soft skills narratives for language arts, mathematics, applied science, and ethics. The primary objective is to present complex technology in easy-to-understand modules using everyday language. Language that might be classified as requiring a higher reading level is only used when it is in common usage in today's truck service and repair industries. When words such as *prognostics* or *telematics* are introduced, they are explained in the core text along with being defined in the comprehensive glossary that appears in the appendices.

Heavy Duty Truck Systems becomes a more effective learning tool for students when used in conjunction with some of the augmented online learning modules. A short video or interactive workplace simulation exercise can often demonstrate a concept in minutes that might take the written word alone much longer. This is especially true when introducing subject matter such as electricity or fluid power basics. Language skills and especially technical literacy are essential in the modern workplace, but sometimes visual simulations and demonstrations can help learners navigate the first steps to grasping a concept.

CHANGES IN TECHNOLOGY

Recent advances in all-electric powertrain technology by Cummins, Motiv (Ford), Tesla, and others, suggest that trucking is taking the first steps away from using fossil fuels. The key to making the Class 8 all-electric truck is battery technology and over the past five years there have been significant advances. While all-electric trucks will be properly introduced in the next edition of the powertrain companion to this textbook, semi- and fully autonomous truck technology is already with us. The Society of Automotive Engineers (SAE) define five levels of autonomous vehicle operation and it should be noted that only Level 5 can be 100 percent driverless. Fully autonomous trucks are not going to become commonplace on our highways in the immediate future, but commercial vehicles categorized as semi-autonomous Levels 1 and 2 are widely in use today. We have had mandatory antilock braking systems (ABS) in trucks and trailers for more than twenty years and ABS is a Level 1 autonomous vehicle technology.

In addition, to identifying the five levels of autonomous vehicle operation in this edition, the coverage on *connected truck technology* is expanded. Electronic logging devices (ELDs) became mandatory in December 2017 and today every OEM equips new trucks with telematics capability. Understanding the connected truck is essential for technicians from the first day they step into a truck service shop. This connectivity is used by federal and state enforcement agencies, by fleets to monitor driver and vehicle activity, by OEMs for the

data mining essential for prognostics, and by drivers for dispatch and location communications.

NEW TO THE 7TH EDITION

In addition to new images and updates to most chapters, some of the key new content added includes:

- Lockout/tagout (LOTO): addresses the OSHA mandate for shops to have both a LOTO policy and worker training in place.
- VRMS: the shop repair and maintenance coding system increasingly adopted by fleets; keys to VRMS code navigation.
- R-1234yf: refrigerant system used in some medium-duty truck and school bus A/C systems.
- Electronic logging devices (ELD): mandated in trucks since December 2017, the emphasis is on shop and technician responsibilities.
- Intelligent wheel hubs (SmartHub): operating principles.
- PicoScope and scopemeters: using oscilloscopes for basic electrical and advanced electronics diagnostics.
- DIN wiring schematics: navigating current track wiring coding and schematics.
- Introduction to SAE's five levels of autonomous truck chassis management.

STUDENT AND EDUCATOR FEEDBACK

The ongoing contribution by users of this book has been invaluable. As it goes into a 7th edition, the book contains hundreds of suggestions that were sourced from

students and instructors. Increasingly, my role as a writer has been to filter feedback and incorporate it into each successive edition. These contributors are mostly educators working in truck, heavy equipment, and diesel programs in the United States, Canada, Australia, and New Zealand, who have taken the time to do something, perhaps as small as to identifying a typo, or as significant as suggesting a different approach to delivering subject matter. Thanks to communications technology, a direct connection to readers is possible and this widespread collaboration by educators makes for better books. Collating and organizing input from a wide range of sources so that it works as an effective teaching tool is important to an author today, as is experience, researching, and writing.

While I am indebted to all my reviewers, a couple deserve a special mention because over multiple editions they have had a major influence in shaping the book's current content. I would especially like to single out Bernie Andringa of Skagit Valley College and John Murphy of Centennial College for their contributions over the years.

Sean Bennett
May 7th, 2018
email@seanbennett.org
www.seanbennett.org

Features of the Text

Learning how to maintain and repair heavy-duty truck systems can be a daunting endeavor. To guide the readers through this complex material, we have built in a series of features that will ease the teaching and learning processes.

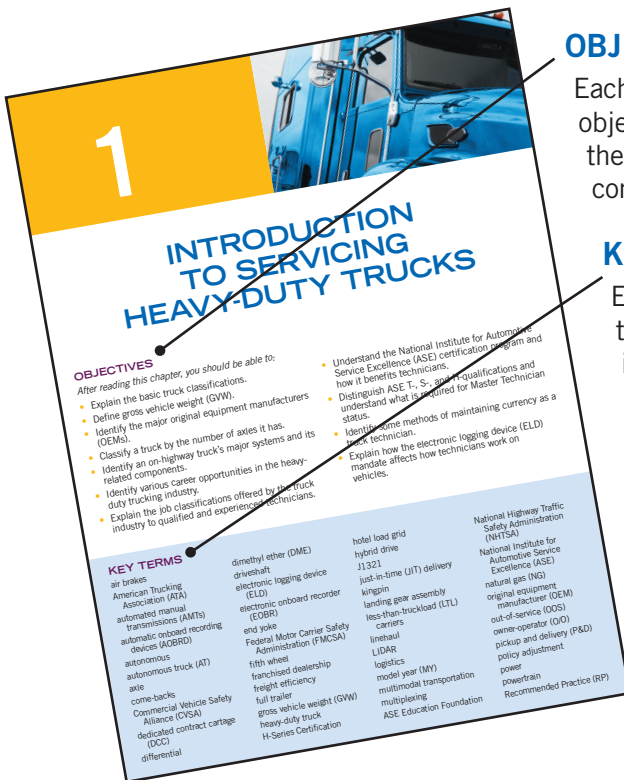

OBJECTIVES

Each chapter begins with the purpose of the chapter, stated in a list of objectives. Both cognitive and performance objectives are included in the lists. The objectives state the expected outcome that will result from completing a thorough study of the contents of the chapters.

KEY TERMS

Each chapter also includes a list of the terms that are introduced in the chapter. These terms are defined in the glossary and highlighted in the text when they are first used.

SHOP TALK

These features are sprinkled throughout each chapter to give practical, common-sense advice on service and maintenance procedures.

WARNING and CAUTION

Since shop safety is the most important concern among instructors, cautions and warnings appear frequently to alert students of safety concerns.

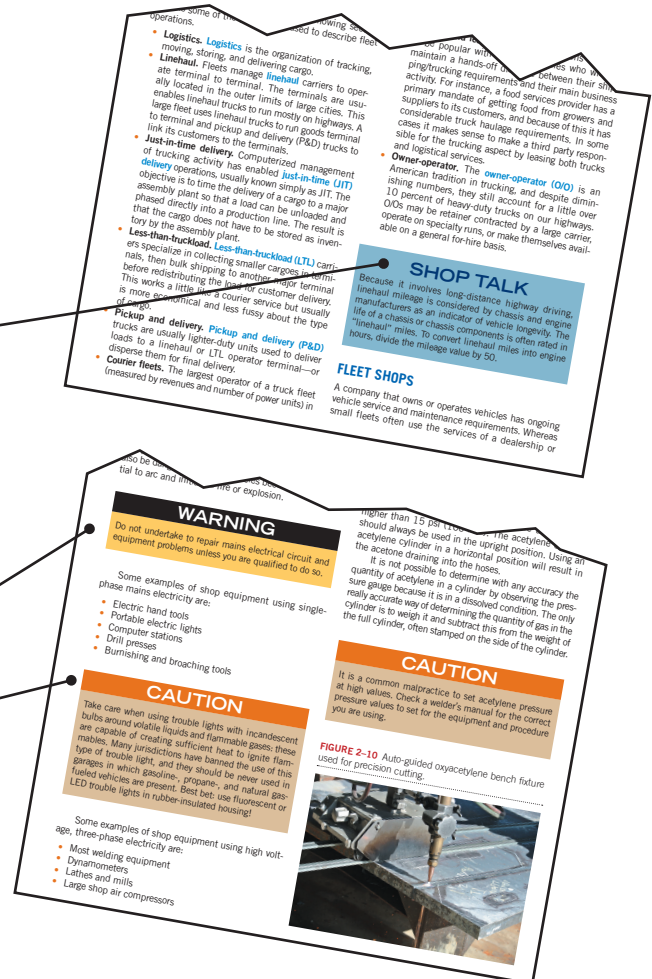

PHOTO SEQUENCE

Step-by-step photo sequences illustrate practical shop techniques. The photo sequences focus on techniques that are common, need-to-know service and maintenance procedures. These photo sequences give students a clean, detailed image of what to look for when they perform these procedures.

SUMMARY 25

truck is easy to manage by a driver with much lower skill levels than those required to drive current Class 9 semi-trailers.

Tesla Driver Experience

Anyone who has driven a hybrid electric vehicle will provide for the superior of-line torque (acceleration) of AC electric motors compared with a conventional diesel-powered truck or bus drivetrain. This element of the driving experience is further improved in an all-electric truck. A bob-tailed Tesla truck is claimed to be capable of a 0-60 mph (0-96 km/h) launch, which is better than that of some performance cars. When the same tractor is coupled to a fully loaded trailer, it can accelerate from 0-60 mph (100 km/h) inside of 20 seconds and hold a 65 mph (100 km/h) road speed while climbing a 5 percent grade. In addition, the driving experience is improved. The driver faces two touch screen displays mounted on either side of the steering wheel; these are used to display the vehicle navigation system and vehicle operational status. In addition, the truck is equipped with full telematics capability known as vehicle to infrastructure (V2I), infrastructure to vehicle (I2V), and vehicle to vehicle (V2V). V2V is a key technology required to enable truck platooning convoys, which are a major energy saver.

SUMMARY

- Although the number of trucks and automobiles in America is increasing, the number of technicians available to service and maintain them is decreasing.
- Trucks are classified by their gross vehicle weight (GVW), the weight of the vehicle and maximum load, and by the number of axles they have. Heavy-duty trucks have a GVW of 26,001 pounds (11,794 kg) or more.
- The major systems in on-highway trucks are engines, shafts, axles, steering, suspension systems, wheels and tires, brakes, vehicle retarders, chassis frame, fifth wheel, heating and air conditioning, electronic controls, and accessories.
- Heavy-duty truck technicians are employed in fleet and operations, fleet shops, dealership shops, independent truck service shops, specialty service shops, and other types of truck shops such as truck leasing and refuse haulers.
- Job classifications in the heavy-duty truck industry include the service technician, who maintains and repairs all systems; the specialty technician, who maintains and repairs a single system; the service technician, who works directly with drivers and communicates with the service technician; the parts manager, who maintains the inventory of parts needed for maintenance and repair; the shop supervisor, who is in charge of the service technicians; and the service manager, who oversees the entire service operation of a large dealership, fleet, or independent shop.
- A successful heavy-duty truck technician must be able to maintain good customer relations and working relationships, use effective communications skills, maintain a safe work environment, perform preventive maintenance, use tools and equipment properly, troubleshoot, and diagnose systems by repairing or replacing, and upgrade skills and knowledge continuously.
- Training for heavy-duty truck technicians is offered by vocational/technical schools, community colleges, and fleet training programs, and manufacturer training programs.
- Heavy-duty truck technicians with at least 2 years of hands-on experience can obtain certification from the National Institute for Automotive Service Excellence (ASE) by passing written exams.
- Technicians should consider joining a professional association such as the Technology and Maintenance Council (TMC) to maintain technical currency.
- SuperTech is a national truck technician rodeo held at the TMC annual fall meeting during which technicians compete for grand champion status.
- Technicians should understand how the ELD mandate affects how they interact with any icy road that exceeds 5 mph.
- Autonomous and semi-autonomous trucks replace, or partly replace, the human driver with computer controls and telematics; they use photo sensors, radar, and lidar to map and track the vehicle surroundings.
- All-electric trucks use advanced battery technology to achieve up to 500 miles range on a single charge. They are simple to operate and can sometimes outperform diesel-powered trucks.

3.5 FASTENERS 91

Photo Sequence 2

REPAIRING DAMAGED THREADS

P 2-1 For this exercise, we are going to look at how to install a Helicoid insert. The first step is to measure the screw pitch using a set of pitch drill gauges. This will determine the size of the procedure.



P 2-2 The above image shows the Helicoid insert. This kit shown includes a double-end adjustable (bar) tap wrench, a T-chuck tap wrench (more compact), a tap, and a Helicoid drive mandrel with an insert.



P 2-3 Helicoid inserts are available for almost any Standard or Metric fastener thread pitch. The above image shows a 1/2-20 inch kit, which includes the appropriate drive tap and tap. The inserts can also be purchased separately at lower cost.



P 2-4 Using the instructions on the Helicoid kit, select the specified drill bit and drill out the existing threads. When drilling into a blind hole such as that shown above, take care not to drill at a depth beyond the existing hole.



P 2-5 Insert the specified tap into a tap bar wrench such as the one shown above. In cases where there is insufficient clearance, a T-type tap driver may have to be used, but these are more difficult to hold square to the hole. In these cases, use a square to ensure that the threads are tapped square.



P 2-6 Ensure that the tapped hole is completely clean. Insert the Helicoid insert into the driver tap threads and lock the driver as shown in the image above.



P 2-7 Rotating the tap driver, turn the Helicoid insert into the newly cut threads.



P 2-8 After insertion, the insert should be fractionally blow flush as shown in the image above.



P 2-9 Finally, check that the specified fastener turns easily into the insert threads. CAUTION: In instances where a thread insert is to be installed into an open hole that must seal, apply an appropriate thread sealant to both the insert and the fastener.



SUMMARY

Highlights and key bits of information from the chapter are listed at the end of each chapter. This listing is designed to serve as a refresher for the reader.

REVIEW QUESTIONS

A combination of short-answer essay, fill-in-the-blank, multiple-choice, and ASE-style questions make up the end-of-chapter questions. Different question types are used to challenge the reader's understanding of the chapter's contents. The chapter objectives are used as the basis for the review questions.

50 CHAPTER 2 SHOP SAFETY AND OPERATIONS

- Take care when oxyacetylene cutting or electric welding and always use protective eyewear with the correct filter shades. Avoid contact with hot metal components, substances and potentially toxic gases.
- Take care when using a hydraulic press. Use protective eyewear. Make sure you are protected by safety cages or barriers.
- The work area should be kept clean, dry, and organized. Flammable liquids and solvents should be handled and stored carefully.
- Emergency telephone numbers and a first-aid kit should be handy.
- Use firefighting equipment appropriately: water or foam chemicals on burning liquids; carbon dioxide or dry chemical agents on burning "live" electrical equipment; and dry chemical agents on burning metals.
- Select, store, use, and maintain shop tools properly.
- Hazardous materials used in heavy-duty truck repair include flammable, corrosive, reactive, and toxic materials. Your employer is obligated to inform you of potential hazards in your workplace, and you have a right to protect yourself from them.
- Specific laws govern the disposal of hazardous wastes, including oil, antifreeze/coolants, refrigerants, batteries, battery acids, acids and solvents used for cleaning, and paint and body repair product wastes. Hazardous wastes may be recycled in the shop or removed by a licensed disposal hauler.
- By law, records must be kept by each shop of the repair and maintenance of trucks involved in interstate shipping.
- Computers have become part of the way of life in truck service shops. They are used for diagnostic routines, order generating, personnel management, and cost tracking.
- Lockout/tagout (LOTO) procedure is required to be incorporated into shop policy as a key to reducing work injuries.
- LOTO policy is designed to protect workers; ignoring or short-cutting LOTO procedures can expose technicians and their colleagues to potential injury.

REVIEW QUESTIONS

- In this book, the sections that contain cautions are labeled with what might result in personal injury?
 - SHOP TALK
 - SAFETY RULES
 - CAUTION
 - WARNING
- The best way to prevent eye injury is to:
 - take care during grinding or other operations that throw off particles.
 - always wear safety glasses.
 - always wear a bump cap.
 - make sure a source of running water is available to flush foreign matter out of the eyes.
- Which of the following describes a safe lifting and travel while carrying your direction?
 - Bend forward to place a heavy object on a shelf or counter.
 - Lift by bending, and then straightening your legs, rather than by using your back.
 - Position your feet as far as possible from the load when you begin to lift.
 - Oil on the floor of the work area can be cleaned up using a _____.
- The exhaust pipe of a diesel engine must be connected to the shop exhaust system to protect against:
 - breathing harmful emissions.
 - carbon monoxide.
 - carbon dioxide.
 - fire.
- Do NOT attempt to put out a Class B fire using:
 - foam.
 - carbon dioxide.
 - a dry chemical type extinguisher.
 - water.
- A Class C fire involves:
 - ordinary combustibles, such as paper or cloth.
 - a flammable liquid.
 - live electrical equipment.
 - combustible metals.
- To use carbon dioxide to extinguish a fire, direct the discharge:
 - at the top of the flames.
 - first at the edge of the fire, then forward and upward.
 - at the base of the flames.
 - several feet over the top of the flames.

Supplements

WORKBOOK

The Student Workbook reinforces the foundations provided by the textbook. In addition to special emphasis on the use of precision measuring tools, the Workbook includes study tips, practice questions, and online tasks to address the increasing importance of networking skills to truck technicians. Finally, in keeping with the objective reinforcing performance skills, the job sheets in the Workbook make the connection between the theoretical concepts in the textbook and the hands-on application of that knowledge, bridging theory with practice. Each job sheet has been correlated with all relevant 2018 ASE Education Foundation tasks.

INSTRUCTOR RESOURCES CD

Carefully prepared, the Instructor Resources CD brings together several time-saving tools that allow for effective, efficient instruction. The Instructor Resources CD contains the following components:

- **PowerPoint®** lecture slides, which present the highlights of each chapter.
- An **Image Gallery**, which offers a database of hundreds of images in the text. These can easily be imported into the PowerPoint® presentations.
- **Lesson Plans** provide chapter-by-chapter ASE Education Foundation correlations, job sheet ASE Education Foundation correlations, chapter overviews, lecture outlines, and answers to the textbook and workbook review questions.
- **ASE Education Foundation Correlations** in which the current ASE Education Foundation Medium/Heavy Truck Standards are correlated to the chapter of the core text and all relevant Workbook Job Sheets.
- **End-of-Chapter Review Questions**, which are provided in MS Word format.

INSTRUCTOR COMPANION WEBSITE

The Instructor Companion Website, found on cengagebrain.com, includes the following components to help minimize instructor preparation time and engage students:

- **PowerPoint®** lecture slides, which present the highlights of each chapter.

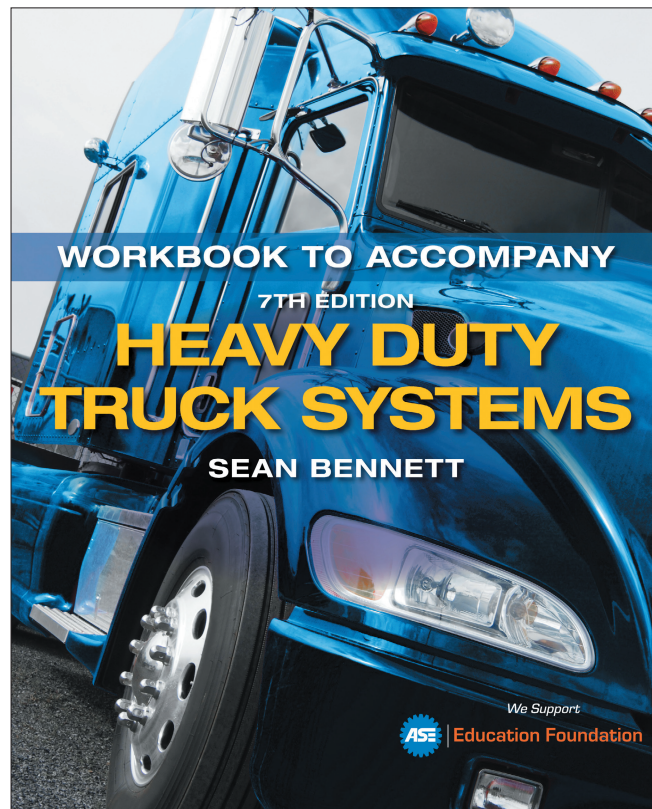

- An **Image Gallery**, which offers a database of hundreds of images in the text. These can easily be imported into the PowerPoint® presentations.
- **Lesson Plans** provide chapter-by-chapter ASE Education Foundation correlations, job sheet ASE Education Foundation correlations, chapter overviews, lecture outlines, and answers to the textbook and workbook review questions.
- **ASE Education Foundation Correlations** in which the current ASE Education Foundation Medium/Heavy Truck Standards are correlated to the chapter of the core text and all relevant Workbook Job Sheets.
- **End-of-Chapter Review Questions**, which are provided in MS Word format.

Cengage Learning Testing Powered by Cognero is a flexible, online system that allows you to:

- Author, edit, and manage test bank content from multiple Cengage Learning solutions.
- Create multiple test versions in an instant.
- Deliver tests from your LMS, your classroom, or wherever you want.

MINDTAP FOR HEAVY DUTY TRUCK SYSTEMS

MindTap is a personalized teaching experience with relevant assignments that guide students to analyze, apply, and improve thinking, allowing you to measure skills and outcomes with ease.

- *Personalized Teaching:* Becomes YOURS with a Learning Path that is built with key student objectives. Control what students see and when they see

it—match your syllabus exactly by hiding, rearranging, or adding your own content.

- *Guide Students:* Goes beyond the traditional “lift and shift” model by creating a unique learning path of relevant readings, multimedia and activities that move students up the learning taxonomy from basic knowledge and comprehension to analysis and application.
- *Measure Skills and Outcomes:* Analytics and reports provide a snapshot of class progress, time on task, engagement and completion rates.

ACKNOWLEDGMENTS

REVIEWERS

We would like to acknowledge and thank the following educators for their insightful suggestions and comments on way to improve the text for the seventh edition:

Arlen J. Crabb
Lincoln College of Technology
Columbia, MD

Mike Dowling
Clark Power Systems,
Wentzville, MO

Gary Greener
Waco, TX

Chad M. Parsons
WyoTech
Laramie, WY

INDIVIDUALS

Tim Allan, Bobcat Toronto
Doug Anderson
Bernie Andringa, Skagit Valley College
Joel Arabzadegan, Volkswagen U.S.A.
Dave Archibald, Navistar International
Kathi Barringer, Allison Transmission
Stephen Belitsos, Vermont Technical College
Joe Bell, John Deere, Iowa
John Bissonnette, Centennial College
Douglas Bradley, Utah Valley State College
Lawrence Brett, Tallman International Trucks
Walter Brueggeman, Tidewater Community College
Darrin Bruneau, Miller Waste Systems
Brian Callopi, Greenville Technical College
Mike Cerato, Centennial College
Dennis Chapin, Roque Community College
Alan B. Clark, Lane Community College
Dave Coffey, Toromont Caterpillar
David Conant, Lincoln College of Technology
Pedro Correiea, Harper DDC-Allison, Toronto
Cameron Cox, SAIT
Arlen J. Crabb, Lincoln College of Technology,
Columbia, MD
Jeff Curtis, Bellingham Technical College
John Dixon, Centennial College
Mike Dowling, Clark Power Systems
Bob Drabecki, Navistar International
Ken DeGrant, Dearborn Group
Dave Drummond, Mack Trucks Inc. (Ret)
Owen Duffy, Centennial College
Casey Eglinton, Western Technical College
Dave Embury, Eaton Dana Corporation
Craig Fedder, Navistar International
Bob Fitzgerald, Ohio Technical College
Lou Gilbert, Allison Transmission
Len Gonzalez, MGM Corporation

Gary Greener, TSTC Waco
Terry Harkness, Toromont Caterpillar
Scott Heard, Fleming College
Jason Hedges, Buckham Transport
Kevin Heimbach, Berks Career and Technology Center
Michael Henich, Linn-Benton Community College
Sergio Hernandez, Palomar College
Rick Higinbotham, Ohio Auto-Diesel Technical College
Paul Hogarth, Nortrax, John Deere
Ted Hrdlicka, Denver Automotive and Diesel College
Kyle Hutchinson, Toromont Caterpillar
Robert Huzij, Cambrian College
Winston Ingraham, University College of Cape Breton
John Kay, Allison Transmission
Kenneth W. Kephart, Central Texas College
Mark Koslan, Texas State Technical College
John Kramer, Centennial College
Bobby Leatherman, NADC, Lincoln South
Roger LeBlanc, Counterbalance Beads
Wayne Lehnert, Universal Technical Institute
Pat Leitner, Freightliner Corporation
Sam Lightowler, Toronto Transit Commission
George Liidemann, Centennial College
Terry Lindsey, Oklahoma State University, Okmulgee
Rolf Lockwood, *Today's Trucking Magazine*
David Lund, Memphis, TN
James Mack, Berks Career and Technology Center
Alan McClelland, Centennial College
Danny McLellan US/CA at ABC
Dale McPherson, East Idaho Technical College
John Montgomery, Volvo-Mack Trucks
Dave Morgan, Centennial College
John Murphy, Freightliner Training
Steve Musser, Wyoming Technical Institute
Gary Nederynan, Orion Bus
John Overing, Michelin Canada

XVI ACKNOWLEDGMENTS

Jim Park, *Today's Trucking*
Chad M. Parsons, WyoTech, Laramie, WY
George Parsons, Sault College
Fred Pedler, Haldex Midland
Roger Perry, Harper, Toronto
Allan Pritchard, Toronto Transit Commission
T. Grant Ralston, Fairview College
Dexter Rammage, Santa Rosa Junior College
Leland Redding, Texas State Technical Institute
Robin Reed, Deutsch Corporation
Robert D. Ressler, Lebanon Co., CTC
Martin Restoule, Algonquin College
Ken Riley, Toromont Caterpillar
Ovi Robotin, Fluke Corporation
Bob Rutherford, Auburn University
Sara Saplin, Wards Forest Media, NY
Ron Scoville, Sargeant Reynolds CC
Wayne Scott, Loblaws Logistics
Tony Simco, Hutchison, UAF
Martin Sissons, Centennial College

Darren Smith, Centennial College
Angelo Spano, Centennial College
John Stone, Washington State Community College
Brian Strach, Hendrickson Corporation
Dan Sullivan, Sullivan Training Solutions
John Tamas, JVS, Oberlin, Ohio
Gino Tamburro, Centennial College
Robert Taylor, Voith Incorporated
Michael Thomas, Arizona Automotive Institute
Alan Thompson, Centennial College
Michael Tunnel, American Trucking Associations
Pierre Valley, Georgian College
Robert Van Dyke, Denver Automotive and Diesel
College
Claude Williams, Toromont Caterpillar
Martin Wilmer, Universal Technical Institute
Deven Wilson, John Deere Training
Gus Wright, Centennial College
Gilles Ybarro, Université Laval

ORGANIZATIONS

The Truck Faculty Team, Lincoln College of
Technology, Nashville
The Truck Faculty Team University of Northwestern
Ohio
The Automotive Faculty Team, WelTech, Wellington,
New Zealand
The Heavy Vehicle Instructor Team, Hunter TAFE,
Kurri Kurri, NSW, Australia

North American Conference of Automotive Teachers
(NACAT)
Technology and Maintenance Council of the ATA
Vermont Technical College
Cambrian College, Sudbury
Centennial College, Toronto
Ohio Technical College, Cleveland

CONTRIBUTING COMPANIES

We would like to thank the following companies that provided technical information and images art for this edition.

APW Engineered Solutions (Power-Packer)
Accuride Corporation
Aidco International, Inc.
Alcoa Wheel Products
Allison Transmission
American Trailer Industries, Inc.
Arvin Meritor
ASE
Battery Council International
Bee Line Co., Bettendorf, IA
Bendix Commercial Vehicle Systems LLC

Bosch GmbH
Bostrom Seating, Inc.
Bridgestone Americas Tire Operations
Bridgestone / Firestone Inc.
Buckham Transport, Millbrook
The Budd Company
Carrier Refrigeration Operations
Caterpillar Inc.
Central Tools, Inc.
Chalmers Suspensions International Inc.
Chicago Rawhide

Clark Power Systems
Consolidated Metco, Inc.
Counterbalance Beads Corporation
Daimler Trucks North America
Dake
Daloz Safety
Dana Corporation
Dearborn Group
Deere & Company
Detroit Diesel Corporation
Dorsey Trailers, Inc.
DuPont Automotive Finishes
Eaton Corporation
Espar Heater Systems
Firestone Industrial Products Co.
Fontaine International
Goodson Tools & Supplies
Gray USA Corp.
Haldex Brake Products Corporation
Harper Freightliner and Detroit Diesel
Heavy Duty Trucking
Hendrickson International
Hennessy Industries, Inc.
Hunter Engineering Company, Inc.
Industrial Seats
Innovative Products of America
Intel Corporation
International Business Machines
International Truck and Engine Corporation
J.J. Keller & Associates, Inc.
JOST International
Kenworth Trucks of Toronto
Kim Hotstart Mfg. Co.
Knorr-Bremse Group
Lubriquip, Inc.
Meritor WABCO
Michelin Tires (Le groupe Michelin)
Midtronics, Inc.
MPSI (Micro Processor Systems, Inc.)
National Seating
NEXIQ Technologies
Paccar Trucks
Penske Truck Leasing Corp.
Premier Peterbilt
Prestolite Electric Inc.
Protectoseal Company
Remy International, Inc.
Robinair, SPX Corporation
RTI Technologies, Inc.
SAF-HOLLAND, Inc.
SKF USA Inc.
Snap-On Tools Company
Stanley Tools, New Britain, CT
Tallman Navistar Truck Center, Oshawa
Toromont Caterpillar Industries
Trailmobile Trailer LLC
Truck Trailer Manufacturers Association
TRW Automotive
Utah Valley State College
Voith GmbH
Volkswagen Academy U.S.A
Vulcan Materials Company
Wagner Brake, Division of Federal-Mogul Corp.
Wards Forest Media
Webasto Product North America, Inc.
White Industries, Division of K-Whit Tools, Inc.
Winslow Gerolamy International Trucks

1



INTRODUCTION TO SERVICING HEAVY-DUTY TRUCKS

OBJECTIVES

After reading this chapter, you should be able to:

- Explain the basic truck classifications.
- Define gross vehicle weight (GVW).
- Identify the major original equipment manufacturers (OEMs).
- Classify a truck by the number of axles it has.
- Identify an on-highway truck's major systems and its related components.
- Identify various career opportunities in the heavy-duty trucking industry.
- Explain the job classifications offered by the truck industry to qualified and experienced technicians.
- Understand the National Institute for Automotive Service Excellence (ASE) certification program and how it benefits technicians.
- Distinguish ASE T-, S-, and H-qualifications and understand what is required for Master Technician status.
- Identify some methods of maintaining currency as a truck technician.
- Explain how the electronic logging device (ELD) mandate affects how technicians work on vehicles.

KEY TERMS

air brakes	dimethyl ether (DME)	hotel load grid	National Highway Traffic Safety Administration (NHTSA)
American Trucking Association (ATA)	driveshaft	hybrid drive	National Institute for Automotive Service Excellence (ASE)
automated manual transmissions (AMTs)	electronic logging device (ELD)	J1321	natural gas (NG)
automatic onboard recording devices (AOBRD)	electronic onboard recorder (EOBR)	just-in-time (JIT) delivery	original equipment manufacturer (OEM)
autonomous	end yoke	kingpin	out-of-service (OOS)
autonomous truck (AT)	Federal Motor Carrier Safety Administration (FMCSA)	landing gear assembly	owner-operator (O/O)
axle	fifth wheel	less-than-truckload (LTL) carriers	pickup and delivery (P&D)
come-backs	franchised dealership	linehaul	policy adjustment
Commercial Vehicle Safety Alliance (CVSA)	freight efficiency	LIDAR	power
dedicated contract cartage (DCC)	full trailer	logistics	powertrain
differential	gross vehicle weight (GVW)	model year (MY)	Recommended Practice (RP)
	heavy-duty truck	multimodal transportation	
	H-Series Certification	multiplexing	
		ASE Education Foundation	

records of duty status (RODS)	splined yokes	Technology and Maintenance Council (TMC)	T-Series Certification
repair order	S-Series Certification	torque	universal joints (U-joints)
semi-trailer	straight truck	tractor	vocational
specialty service shops	SuperTech		wheel end
	suspension		work order

INTRODUCTION

According to the U.S. Department of Transportation (DOT) the total number of registered highway vehicles exceeded 264 million vehicles in 2016. More than 15 percent of this total is made up of trucks and trailers used primarily for commercial purposes. That represents close to 40 million vehicles. In 2014, total registrations for Class 8 trucks alone exceeded 3.66 million units. For most of the past three decades, through periods of boom and recession, a shortage of truck technicians has existed throughout the continent. This shortage of technicians is worsening as the median age of those employed in the trucking industry increases. For a number of years, the trucking industry has retired more personnel than it recruits and in some areas of the country there are significant shortages. Although this may be bad news for freight transportation managers, it is good news for anyone wanting to get into the industry especially for those willing to move to those areas in which there are jobs available. Job opportunities, rates of pay, and potential for advancement in the trucking industry have never been better. Although the modern highway truck requires much less frequent service work to keep it in top mechanical condition than the truck of a generation ago, most of that service work performed by a truck technician today requires a higher level of skills.

Good truck technicians are in high demand. Today a good truck technician is required not just to diagnose and repair trucks but also to be computer literate, to regularly update technical knowledge, and to practice customer service skills. Perhaps more than any other

skill set, the skill most required of the modern truck technician is that of being a lifelong learner to keep abreast of the fast-changing technology of this industry. One of the objectives of this chapter is to outline some of the strategies both student and certified technicians can use to maintain technical currency.

1.1 TRUCK CLASSIFICATIONS

For purposes of registering commercial vehicles for highway use, trucks are classified by their **gross vehicle weight (GVW)**. GVW is the maximum allowable weight of the vehicle including the weight of the load it can legally carry. There are three classes of “light-duty” trucks, three classes of “medium-duty” trucks, and two classes of “heavy-duty” trucks (**Table 1–1**). A **heavy-duty truck** has a GVW of 26,001 pounds (11,794 kg) or more.

ORIGINAL EQUIPMENT MANUFACTURERS

There are four major truck manufacturers of medium- and heavy-duty trucks in North America. We refer to these manufacturers by the term **original equipment manufacturer (OEM)**. In addition, the four major OEMs are being joined by import OEMs such as Toyota/Hino. None of the import OEMs as yet offers the full range of weight class classifications but this is expected to change. **Table 1–2** lists the major truck manufacturers of Class 8 heavy-duty trucks and their respective market share.

TABLE 1–1 Truck Weight Classifications

General Designation	Weight Category	Standard GVW (pounds)	Metric GVW (kilograms)
Light-duty	Class 1	up to 6,000 GVW	up to 2,722 GVW
	Class 2	6,001–10,000 GVW	2,722–4,535 GVW
	Class 3	10,001–14,000 GVW	4,535–6,350 GVW
Medium-duty	Class 4	14,001–16,000 GVW	6,350–7,257 GVW
	Class 5	16,001–19,500 GVW	7,257–8,845 GVW
	Class 6	19,501–26,000 GVW	8,845–11,793 GVW
Heavy-duty	Class 7	26,001–33,000 GVW	11,794–14,970 GVW
	Class 8	33,001 GVW and over	14,970 GVW and over

TABLE 1-2 Market Share by OEM: Class 8 Trucks

Annual North American Market Sales Percentage in January 2018 Reported by Transport Topics Magazine.			
OEM Corporation	% Total	Brand	% Total
Daimler AG	38.8%	Freightliner	36%
		Western Star	2.8%
DAF-Paccar	29%	Peterbilt	17.3%
		Kenworth	11.7%
International Trucks	14.9%	Navistar	14.9%
Volvo-Mack	17.5%	Mack Trucks	8.5%
		Volvo Trucks	8.8%

AXLE CLASSIFICATIONS

The term **tractor** is used to describe a highway truck that is designed to haul a trailer. The term **straight truck** is often used to describe a highway truck not designed to pull a trailer. Trucks are also classified by the number of axles, the number of wheels, and the number of drive wheels. For example, a tractor with a tandem (close-coupled pairs) rear axle will be either a 6×2 or a 6×4 . The first number refers to the total number of wheels (or sets of wheels in the case of dual wheels). The second number indicates the number of wheels that are driven by the vehicle **powertrain**. The powertrain consists of the engine, clutch, transmission, drive shafts, differentials, and drive wheels.

FIGURE 1-1 A MY 2017 Class 8 highway tractor

A tractor with tandem rear axles (total of 3 axles) where only one axle is driven by the powertrain would be classified as a 6×2 ; it has six wheels, but only two wheels (one axle) drive the vehicle. This classification method is no different from that used to describe smaller vehicles. Most of us are familiar with the term “ 4×4 ,” which is the common means of describing four-wheel drive in an automobile or pickup truck. On the highways the most common heavy truck axle classification is the 6×4 Class 8 truck, as shown in the example in **Figure 1-1**. A 6×4 vehicle consists of three axles: a forward located steering axle and a pair of rear drive axles. The truck shown in Figure 1-1 is a highway tractor while **Figure 1-2** shows some types of vocational trucks

FIGURE 1-2 Examples of on-highway vocational trucks

TABLE 1-3 Truck Classification by Wheel Number

Motor Vehicle	Total Wheels	Driven Wheels	Total Axles	Drive Axles
4 × 2	4	2	2	1
4 × 4	4	4	2	2
6 × 2	6	2	3	1
6 × 4	6	4	3	2
6 × 6	6	6	3	3
8 × 4	8	4	4	2
8 × 6	8	6	4	3

trucks. A tractor is designed to haul trailers. **Table 1-3** lists the common axle-wheel configurations and their driven wheels and axles.

6 × 4 versus 6 × 2 versus 4 × 2

Up to the present day the most common highway tractor is the 6 × 4 configuration, but a shift toward improved fuel economy is beginning to change this. Outside of North America there has been wider acceptance of 4 × 2 tractor units and this is related to lower cargo payload limits and better fuel economy. Comparative fuel economy usually references the SAE **J1321** test, which attempts to ensure that strict rules are used to evaluate fuel consumption tests in commercial trucks. Comparative advantages and disadvantages of each configuration based on J1321 testing and simplified are listed in **Table 1-4**.

Trailers

There are many trailer designs, sizes, and applications. A majority of the trailers we see on our highways are **semi-trailers** such as that shown in **Figure 1-3**. A semi-trailer is one that depends on the tractor to support at least some of its weight. The semi combination shown in Figure 1-3 is the most common truck configuration seen on our roads. In this figure, a dual axle semi-trailer is being hauled by a 6 × 4 tractor in an arrangement we know as an “18-wheeler.”

TABLE 1-4 Comparative Advantages of Highway Tractor Configurations

	6 × 4	6 × 2	4 × 4
Fuel efficiency	Lowest	Medium	Best
Traction	Best	Medium	Lowest
Maneuverability	Least	Least	Best
Payload	Highest	Medium	Lowest

FIGURE 1-3 Tractor-trailer combination: a dual axle semi-trailer coupled to a 6 × 4 tractor. This is the most common rig observed on our highways



The less common **full trailer** fully supports its load; in other words, a full trailer does not rest a portion of its weight on the tractor (or trailer in a train combination) hauling it.

Freight Efficiency

The most common type of trailer is the semi van trailer. For a couple of generations, 48-foot trailers were dominant on our highways. However, since the acceptance of 53-foot trailers by most jurisdictions in 2007, companies rapidly renewed their trailer fleets to take advantage of the increased cargo volume and potential to reduce fuel consumption per ton hauled. Today, the term **freight efficiency** is being used to justify heavier loads, longer trailers, and multiple trailer combinations, a trend that is likely to continue. Most of the trucking industry favors replacing the term *fuel economy* by *freight efficiency*, because it is more accurate. Freight efficiency factors the volume and weight of cargo hauled to fuel consumed, rather than the more vague miles-per-gallon equation of vehicle fuel economy. Also due to its potential to reduce handling costs, multimodal transportation systems are rapidly increasing in popularity.

Multimodal Containers

Multimodal transportation refers to containers that can be moved by truck, railway, ship, and even aircraft while keeping load and unload costs to a minimum. Containers are ideal for stacking on ships and railway flatbeds but a primary design consideration is adaptability to haulage by transport truck. Following the acceptance by most jurisdictions of 53-foot highway trailers, there has been a shift toward 53-foot multimodal containers. There is a wide range of specialty trailers, including dry bulk carriers, refrigerated trailers (reefers), and tank trailers as shown in **Figure 1-4**. We take a closer look at the many different types of trailers in Chapter 33.

FIGURE 1-4 A five-axle tanker semi trailer coupled to a tractor: weight-over-axle restrictions by some jurisdictions requires multiple trailer axles



Rig Dimensions

Tractor and semi-trailer dimensions are provided in **Figure 1-5**. An important consideration in determining tractor/semi-trailer dimensions is the distance between the two vehicles when coupled. There must be sufficient clearance between the tractor cab and semi-trailer front

(nose) as well as between the rear of the tractor and semi-trailer **landing gear assembly** to allow for sharp turns and the effect of grade changes.

1.2 HEAVY-DUTY TRUCKS

Heavy-duty truck technicians need to understand the systems and components that power or move, slow and stop, control, direct, support, and stabilize a tractor/trailer combination. **Figure 1-6** shows some of the components discussed in this book. The following major systems are found in on-highway trucks. More information on the classification of trailers can be found in Chapter 33.

COMMERCIAL TRUCK DATA

In 2017, the trucking industry accounted for 79.8 percent of the freight revenues in the United States and Canada, generating \$676 billion. Air, sea, and rail freight combined accounted for the remaining 20 percent. The nearly 40 million registered trucks on our roads paid over \$40 billion to state and federal coffers in the form of user fees and taxes, along with consuming over 38 billion U.S. gallons of fuel. It is in no way misleading to say that the economy of the United States runs on trucks!

FIGURE 1-5 Truck/trailer dimensions and terms

Dimensions	
A	Distance from centerline of rear axle to centerline of body and/or payload. Centerline of body (as $\frac{1}{2}$ body length)
AF	Center of rear axle to end of frame
BA	Bumper to centerline of front axle
BBC	Bumper to back of cab
BL	Body length
CA	Back of cab to centerline of rear axle or tandem suspension
CE	Back of cab to end of frame
CFW	Back of cab to centerpoint of kingpin hole in 5th wheel
CT	Back of cab to front of semi-trailer in straight-ahead relationship
FH	Frame height
FW	Centerline of rear axle or tandem to centerpoint of 5th wheel
KP	Kingpin setting—front of semi-trailer to centerpoint of kingpin on semi-trailer
LGC	Landing gear clearance—center point to nearest interference point
OAL	Overall length
OWB	Overall wheel base
TL	Semi-trailer length
WB	Wheel base—distance between centerline of front and rear axle or tandem suspension

Terms	
Chassis:	Basic vehicle-cab, frame, and running gear
Body:	Container in which the load is carried
Payload:	Commodity to be carried
Curb weight:	Finished vehicle weight, excluding cargo or occupants
Body weight:	Weight of complete body to be installed on chassis
Payload weight:	Weight of commodity to be carried
Gross vehicle weight (GVW):	Total or curb, body, and payload weight

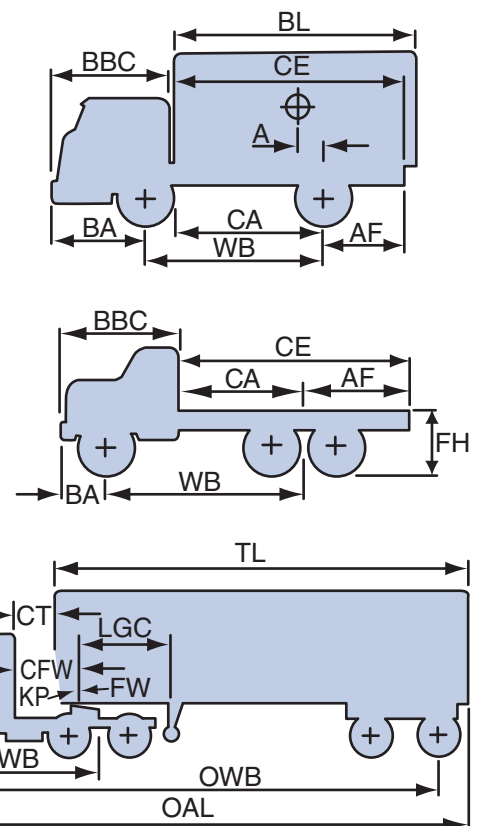
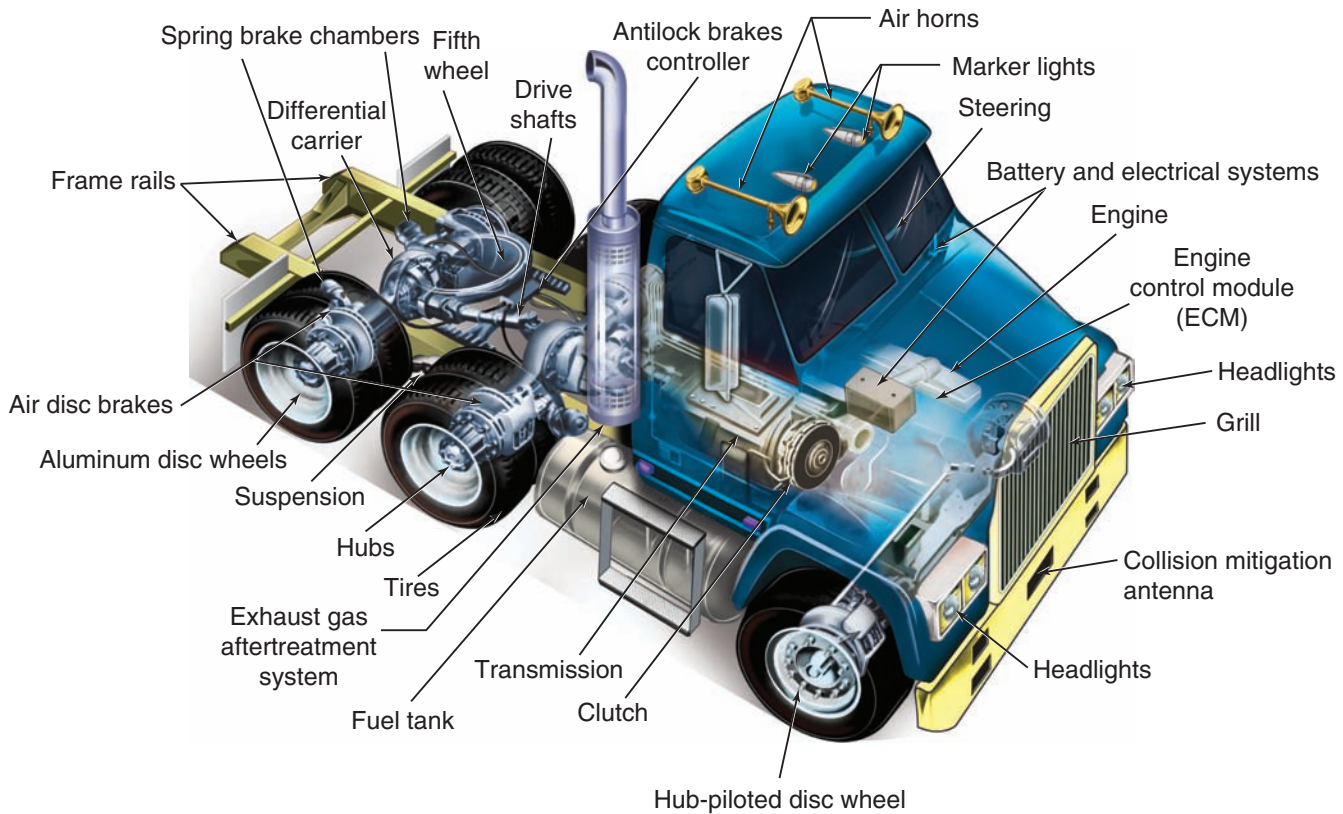

FIGURE 1-6 Some of the components found on a Class 8 heavy-duty truck

Of the registered commercial trucks, Class 8 trucks account for about 10 percent, or 3.68 million, of the total. In the United States today, 7.4 million workers are employed in trucking-related occupations: as drivers and technicians, as well as in logistics, manufacturing, and management. While the large fleets attract more focused attention, it is interesting to note that the trucking industry is primarily made up of small businesses:

- 91 percent of motor carriers operate 6 or fewer trucks
- 97 percent of motor carriers operate fewer than 20 trucks

While dominating freight revenues, trucking also dominated domestic freight tonnage, moving just under 70 percent of the total tonnage.

ENGINES

Current commercial heavy-duty trucks are powered almost exclusively by diesel engines. In fact, most commercial medium- and light-duty trucks also use diesel power today. However, in recent years, the abundance of less costly, domestically sourced **natural gas (NG)** is making some fleets consider NG-fueled engines: the downside is a less developed fueling and repair infrastructure.

For this reason, it has been adopted as an ideal fuel for city transit applications, especially on the West Coast. Volvo have recently introduced **dimethyl ether (DME)** fueled trucks to provide another alternative fuel option. Like NG, DME is composed primarily of methane, but it can be sourced from waste biomass fermentation.

Regardless of the fuel used, all engines today are computer controlled, and diesel power will be the engine of choice for the foreseeable future. Diesel engines cost less to operate, are more dependable, require less downtime for repairs, and are capable of generating a combination of more **power** (140 to 600 horsepower for on-highway trucks) and **torque** (180 to 2,000 lb-ft.) than equivalently sized NG or gasoline engines. *Power* specifies the engine's ability to move, or propel, the vehicle and is measured in horsepower. *Torque* is the potential ability of a rotating element (gear or shaft) to overcome turning resistance and is measured in pounds per linear foot. It is twisting force.

Current highway diesel engines are electronically controlled—that is, computer controlled—such as the example shown in **Figure 1-7**. Electronic controls maximize power output while minimizing emissions. In addition, various engine support systems such as air intake, fuel injection, exhaust, lubrication, and cooling work together to keep the engine running properly. **Figure 1-8**

FIGURE 1-7 Current heavy-duty, Class 8 trucks are powered by computer-controlled diesel engines such as this Detroit Diesel DD15

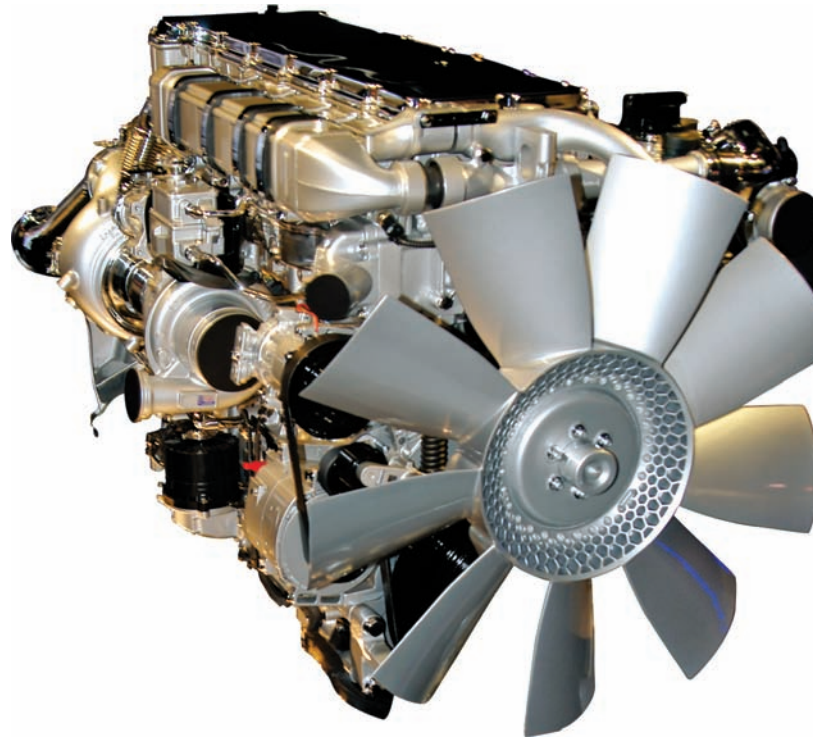

FIGURE 1-8 Open-hood view of the engine compartment in a current diesel-powered truck



shows the engine compartment of a current Class 8 highway tractor.

Hybrid Drive

Hybrid drive technologies have been introduced recently. Hybrid drive systems make a lot of sense in specialized vocational trucks used in inner city, stop-start applications. They also have been embraced by urban

transit authorities interested in reducing emissions and lowering fuel costs. Hybrid drive systems used today can be divided as follows:

- Diesel electric series drive: consists of a small diesel engine powering a generator/motor and battery bank. Vehicle can only move under electric motive power.
- Diesel electric parallel drive: consists of a small diesel engine powering a generator/motor/battery bank and mechanical drivetrain. Vehicle can option electric or engine drive. It is the most common technology used in hybrid urban transit buses.
- Diesel hydraulic series drive: consists of a small diesel engine powering a hydraulic motor/pump and accumulator. Vehicle can only move under hydraulic motive power.
- Diesel hydraulic parallel drive: consists of a small diesel engine powering a hydraulic motor/pump and mechanical drivetrain. Vehicle can option hydraulic or engine drive. It is the most common technology used in hybrid urban pickup and delivery vehicles.

This textbook covers heavy-duty chassis systems but does not include information on commercial vehicle engine systems. This information is covered in a companion textbook (*Medium/Heavy Duty Truck Engines, Fuel, and Computerized Management Systems, Fifth Edition*).

Alternative Fuel Vehicles

Despite the advantage of lowering emissions, especially in short haul and delivery applications, the market popularity of alternative fuel commercial vehicles is, to some extent, tied to the cost of petroleum. Current alternative fuel commercial engines are:

- Propane
- Liquified natural gas (LNG)
- Compressed natural gas (CNG)
- Dimethyl ether (DME)

Unlike the preceding technologies, hydrogen-fueled vehicles produce zero emissions during combustion; however, large quantities of electricity are required to electrolytically manufacture hydrogen from water, so the means of producing the electricity must be considered. In addition, storing hydrogen onboard a truck chassis is challenging due to the high compression pressures. That said, most of the engine OEMs are currently testing hydrogen-powered, vehicles, so it is only a matter of time before they appear on our roads. **Figure 1-9** shows a propane-fueled pickup and delivery van.

ELECTRICAL SYSTEMS

The batteries, alternator, and starter must be sized to match the operating requirements of the engine and chassis electrical systems. Coverage of truck electrical and electronic systems appears in Chapters 5 through 11 in this textbook. Most heavy-duty trucks have between two and four batteries to supply current for the starter

FIGURE 1-9 Propane-fueled pickup and delivery van



motor. Some older trucks have 24-volt starters that require a series-parallel switch in the system. In addition, the electrical systems of heavy-duty trucks provide electricity to operate such safety components as lighting, windshield wiper motors, and gauges plus the operation of the computers, accessories, and tractor cab amenities.

CLUTCHES

Most current heavy-duty trucks use either a push- or pull-type clutch, but more recently, centrifugal and wet clutches have been integrated with some types of transmission. Trucks equipped with high-torque engines and designed to haul heavy payloads use a two-plate clutch. Two-plate clutches double the friction contact area of the clutch compared with a single-plate clutch. The additional friction contact surface area is necessary to transmit high torque to the transmission without slippage. Lighter-duty trucks may use a single-plate clutch assembly. Clutches used with automated manual transmissions are managed electronically but most use the same fundamental principles as mechanical clutches.

TORQUE CONVERTERS

Torque converters are used to transmit engine torque to fully automatic transmissions. Automatic transmissions are not as widely used in commercial trucks as they would be in automotive applications but they are more common in transit bus and vocational truck applications. Torque converters are fluid couplings that use hydrodynamics to multiply the input to output torque ratio.

TRANSMISSIONS

Heavy-duty truck transmissions can be classified as:

- Conventional
- Semiautomated
- Automated
- Fully automatic

Transmission gears, shafts, bearings, forks, and other internal components must perform for thousands of hours, hundreds of thousands of miles, year after year. It is not unusual for a truck transmission to run for a half million or even a million miles with little maintenance other than checking lubrication levels and observing drain intervals.

A majority of heavy-duty trucks are equipped with standard (manual) transmissions (see Chapter 15) but many of these are computer-controlled, automated units known as **automated manual transmissions (AMTs)**. In addition, the market share of electronically controlled fully automatic transmissions continues to increase. Depending on engine output, the intended application

of the vehicle, and the terrain over which it must operate, a commercial truck transmission might have from six to twenty forward gears.

Conventional Transmissions

Conventional transmissions have two or three countershafts that transmit engine torque from the input shaft to the output shaft. This divides the torque two or three ways so that there is less stress on individual gears, extending the service life of the transmission. Conventional transmissions are ratio shifted directly by the driver, sometimes assisted by pneumatic (air) pressure. For this reason they are sometimes known as manual transmissions.

Automated Manual Transmissions

Automated manual transmissions (AMTs) adapt a conventional standard transmission platform to electronic controls. The guts of the conventional transmission remain unchanged. However, the unit is adapted so that the responsibility of selecting and shifting ratios is electronically controlled. Automated transmissions are categorized as:

- **Semiautomated:** also known as three-pedal automated transmissions because the driver is required to use the clutch under some circumstances. These were the first generation of AMTs.
- **Automated:** commonly known as two-pedal automated transmissions because the clutch is actuated automatically, eliminating the clutch pedal.

Automatic Transmissions

Most automatic transmissions use planetary gearsets to transmit drive torque through different ratios. They are coupled to the engine by a type of fluid coupling known as a torque converter. Fully automatic transmissions are initially high-cost components, but in vocational applications, which require constant shifting, they are often cost effective over time. In 2014 to address the gearing requirements of Class 8 tractors, Allison introduced an innovative power-shift automatic transmission that uses a combination of conventional and planetary gearing.

Computer-controlled, automated, and automatic transmissions are becoming increasingly popular, in part due to a shortage of truck drivers and retaining existing drivers. Electronically managed shifting tends to be popular with new generation, younger drivers. Computer-controlled transmissions require a lower level of driver skills and reduce driver fatigue. In addition, they are not vulnerable to shifting abuse practices that often shorten the life of conventional transmissions. **Figure 1–10** shows an electronically controlled, fully automatic Allison transmission.

FIGURE 1–10 An Allison computer-controlled transmission

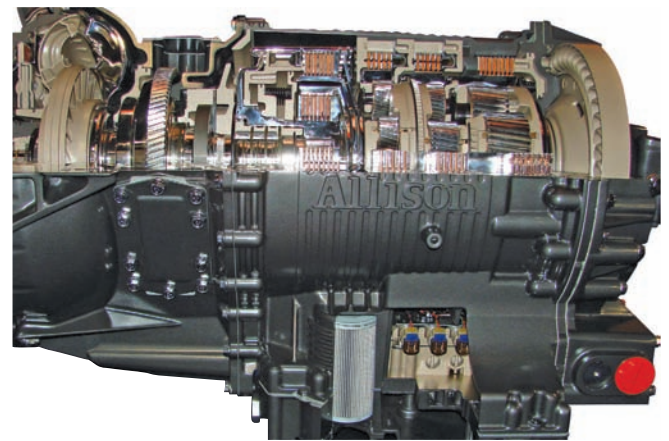

DRIVE SHAFTS

A flange or **end yoke** splined to the output shaft of the transmission transfers engine torque to the drivetrain (see Chapter 22). The **driveshaft** is a hollow tube with end yokes welded or splined to each end. **Splined yokes** allow the drive shaft to increase and decrease in length while rotating to accommodate movements of the drive axles. Sections of the drive shaft are connected to each other and to the transmission and differentials with **universal joints** (“U-joints”). The U-joints allow torque to be transmitted to components that are operating on different planes.

AXLES

Axles provide a mounting point for the suspension system components, wheels, and steering components. The drive axles also carry the **differential** gearing and axle shafts (**Figure 1–11**). The differential transfers the motion of the drive shaft, which is turning perpendicular (at a

FIGURE 1–11 Axle and drive shaft components

